

Smart Mirror for Security and Home Appliances

A. Akhila¹, V. Siva Nagaraju²

¹Department of electronics and communication engineering Institute of Aeronautical Engineering, Hyderabad-500043, India

²Department of electronics and communication engineering Institute of Aeronautical Engineering, Hyderabad-500043, India

¹akhila.aligeti406@gmail.com, ²vsnr2k4@gmail.com

Abstract: *The aim of the paper is design and develop a smart mirror for security and home appliances. The present generation devices are built with smart capabilities. The intelligence is embedded in them to act wise in deployed environment. Mirrors are basically used in home for the purpose of grooming up or getting ready for the day. The same mirrors can be made to behave Smart to provide Security and control home appliances in deployed environment. The proposed system is designed using Raspberry Pi, Camera, raspberry Pi compatible touch screen, microphone as major hardware components and Python for programming. The system can accept three modes of input commands namely touch, Mobile commands and voice commands. Touch screen commands can be used whenever an administrator/owner is in front of the mirror. The mobile based controls can be used when the administrator/owner of the mirror is away from the mirror. The voice commands can be used whenever the person is busy in work. Basically, the work of smart mirror is to display date, time on it and to provide security with the help of camera which is inserted behind the smart mirror and can also operate house hold appliances using this smart mirror. The basic theme of the proposed model is that, to make use and control of household appliances and providing security.*

Keywords: *Smart Mirror; Raspberry Pi; Security; Touch screen.*

1. INTRODUCTION

The world around us is constantly changing. While the advancements in science and technology, we are moving towards a more automated way of life. We have smart cities, smart phones, smart cars, and more. With the advancement in technology, it is learnt that most of the equipment's have become smart. The introduction of smart behavior in present devices have made them most admired and has increased their usability. This fast of life requires the development of smart mirror for security and home appliances.

Further, the system proposed is interactive in nature, hence the user even while grooming up, can give voice commands, to get required and related information on screen, keeping his/her hand free. There are related products available in market, but the main difference lies in the usability of the product. The available products are mostly passive in nature with little interactivity. The present Smart mirrors designed so far are almost passive in nature. These systems can display the information on the screen. They have been designed mostly with Raspberry Pi, LCD (Liquid Crystal Display) or LED (Light Emitting Diodes) for information display. Few of them work on either voice-based commands or Touch Commands or Mobile device commands. Some of the systems are also designed for providing security using PIR

sensors. But the systems thus designed have more false alarm rate and sensing range is also exceptionally low.

The proposed system is an interactive system which displays the date, time on the screen. The display can be customized based on the requirement. The system accepts any of the commands namely voice, touch and mobile control commands and behaves interactively. The proposed system can be controlled by any of these commands. Whenever security systems and household appliances are embedded into household devices like mirror, the usability of device will increase. It can be used for general use and for specific use like providing security in home environment. Usually, intruders and thieves look for security cameras. If they find cameras, they may destroy them and come to know that they were under security monitoring system. But for proposed system, intruder or thief will never come to know that he is under security observations. Normal Cameras will be visible to intruder, but Smart mirror which just looks like an ordinary mirror will not catch an attention of the intruder. Thus, the camera fitted on top of the Smart Mirror will capture the photo of an intruder and be able to send an alert of the intrusion without knowledge to the intruder. The intruder will never come to know that he is under constant surveillances. Home automation are mainly created using intelligent IOT devices, IOT is an integrated system of communicating devices in which each device can carry out tasks by themselves. Smart mirror for home automation has great potential to enhance user experience for accessing and interacting with information. This system is especially useful for physically challenged people, old people, and children. Everyone can easily access this system easily even while doing their daily chorus. This is one of the major advantages of the system.

The proposed system does human identification for detecting the intrusion detection. Once the intruder comes under the range of camera, the intrusion detection takes place. The range of pi-camera which is compatible with raspberry pi is approximately 8m to 10m. Human detection is done. The Human presence thus detected is informed to owner of the Smart mirror through alert message. The alert message consists of photo of intruder along-with the time stamp of time. The Raspberry Pi is to be connected to Wi-Fi and mobile device must be connected to internet.

2. LITERATURE REVIEW

Several related works have been already taken up in this field. The smart mirrors proposed and implemented so far are having variety in terms of hardware and mode of operation. Mirrors capable of accepting voice command via the microphone are built with Raspberry Pi microcontroller, LCD or LED monitor and acrylic two-way mirror. It displays the weather, time, and location information on the screen. Some Smart mirrors are having MCU (Multi Control Unit) units, built with Raspberry Pi and can display weather and latest news updates on the screen. Sensors like Humidity and Temperature sensors used. Multimedia enabled Smart Mirrors are designed which accept voice commands make use of concepts of Artificial Intelligence. The designed System alerts about weather and capable of suggesting the user based on weather. The suggestions are displayed on the mirrors. Webpage based mirror are designed and are customizable. These accept voice commands and use ready APIs of website. Google Assistant is used here, and details of user are stored in the database.

Some mirrors designed for health monitoring devices. These can be used to track weight and fitness of human being. Notable features of the system are Face Recognition, GPS navigation, Bluetooth Connectivity, and wireless communication. For improved communication SONUS technology is used. Hermione 1.0 is used for designing some mirrors. It is an extension of domestic mirror like a Magic Mirror. The voice-controlled system is used as a Home Assistant. Some systems are developed using Python and Java

script programming and tool such as Node.js. System is voice command based smart mirror. Some Smart Mirrors are Voice controlled, can display personalized date and information, and provide real-time update of news and headlines. Some systems use Raspberry Pi and SMT32F030CT8T6 microcontroller as controlling units. These are Voice controlled mirrors with special Speech Synthesis module being implemented using SYN6288 chip.

Smart mirror is designed with speech recognition, face recognition, wake-up touch and voice enabled. Some mirrors operate in two modes namely Display mode and Register Mode. System makes use of MVC model and used in college for student information and registration. System is designed for Theft Detection in a home environment. Human motion is detected by the PIR sensors and later the camera captures information and stores in drop box. The DHT22 hardware chip is used for theft detection and for mobile control, the VNC viewer is used. Some Smart Mirrors are based on AI (Artificial Intelligence) are voice command controlled with support of Human gestures produce real-time information. The system is made responsive by making use of the Machine Learning Techniques. Some systems are designed as Child Monitoring Systems. The system connects to user's smart phone using android application and produces real-time data. The systems proposed so far are built using different algorithms and different hardware units. These systems are primarily meant for displaying information on the screen. The proposed system displays real-time data on the screen and provides security and vigilance in a deployed environment.

3. IMPLEMENTATION OF THE PROPOSED MODEL

It is built with Raspberry Pi as a main controlling unit. The raspberry Pi is physically connected to all the devices like camera, SD card, touch screen and microphone. The raspberry Pi is like a general purpose computer with limited capacity in terms memory and processing.

3.1 Block Diagram

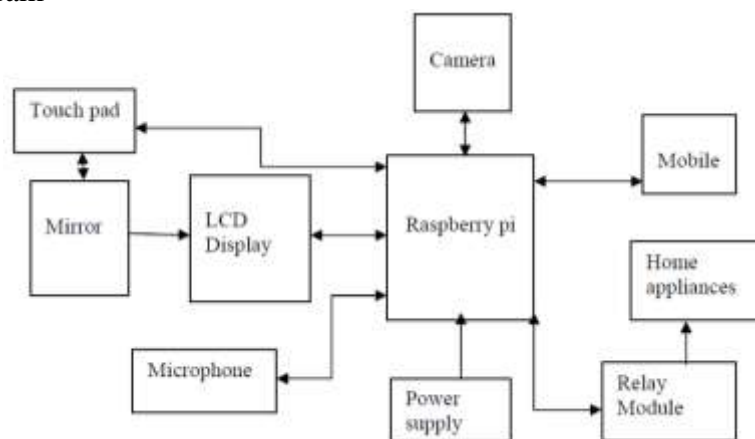

Fig. 1. Detailed Block Diagram.

The commands to this system are given in three modes namely touch commands, voice commands, mobile commands. After validation the commands are sent to Raspberry Pi for execution. The proposed Smart Mirror is specifically designed for providing security in the home environment and to control home automation.

The Raspberry Pi compatible camera is fitted on to the Smart Mirror. The camera will be constantly observing for Human Detection with the help of raspberry Pi. Using the Yolo Object Detection Algorithm, Intrusion is detected. If Intrusion is confirmed, an alert message along with the photo of an intruder is sent to the owner of the Smart Mirror on his registered mobile device. The system can be operated using Voice Commands, touch commands and

can be controlled through Mobile device. The voice or Mobile commands are used to put the System in Intrusion detection (Security)mode. When we give some voice command at that time the microphone will capture the command send it to Google assistant. Then Google assistant will process the command and according to that operation will perform. The processed signal is passed from raspberry pi to relay module and relay module will turn ON/OFF light by using its channels. Speakers are connected to raspberry pi and provides audio to user. Power supply is used to power up raspberry pi. The proposed system consists of the modules namely Authentication module, Input module and Security/Intrusion Detection Module.

A. Authentication Module:

The authentication module is responsible for authenticating the user to the system. The authentication is username and password based. After successful attempt, users will be able to access the Smart Mirror. Figure 4 shows the details of authentication process. If there are 3 unsuccessful attempts, an alert message will be sent to the owner of the system. Once the authentication is successful then the system is ready to accept command. The synchronizer will take care of the commands being issued to the system.

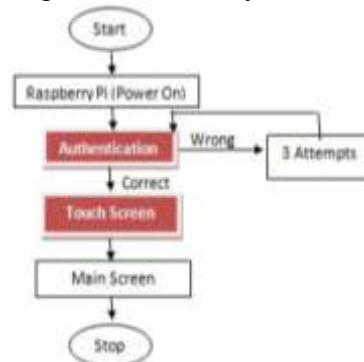

Fig. 2. Authentication Module

B. Input Module:

The figure 5 shows the Synchronizer unit and the functionality of the same.

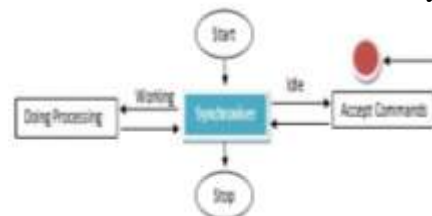

Fig. 3. Synchronizer Unit

The synchronizer unit will accept input commands only if it can serve the command at that state of execution. Usually smart mirror will be in processing phase whenever it is executing the commands. If it is in idle state it will accept commands. The figure shows the ways in which input commands can be issued to the proposed system.

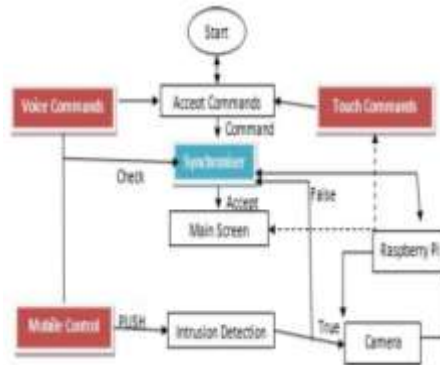

Fig. 4. Input Module

The three modes of input are voice based, touch based and commands through mobile. At any point of time any one of the above said command modes can be used to issue commands to the system. Commands will be executed and results are displayed on the touch enabled screen.

C. Security module/Intrusion detection modules

This is the main theme of the proposed module. This module shows the actual interactive behavior of the proposed system. The figure shows the security module.

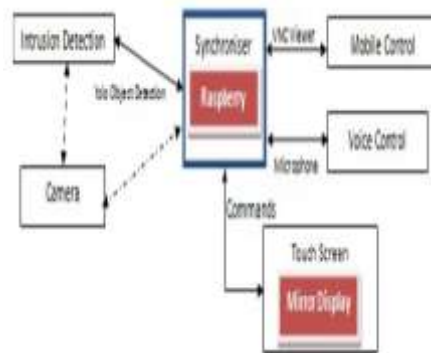

Fig. 5. Security Module

Either voice or mobile commands can be used to operate the intrusion detection system. Voice commands can be issued whenever the user is in front of the system. Mobile commands can be used whenever the user is away for the system.

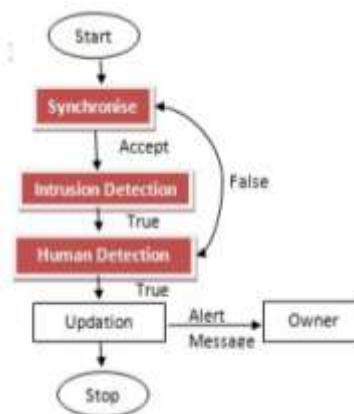

Fig. 6. Human Intrusion Detection

D. Result

The proposed model has been successfully designed and tested. Integrating features of all the hardware components used have developed it. Presence of every module has been reasoned out and placed carefully thus contributing to the best working of the unit. Secondly, using highly advanced IC's and with the help of growing technology the paper has been successfully implemented.



Fig. 7. Smart mirror

4. HARDWARE DESCRIPTION

4.1. Raspberry pi

The raspberry pi is a series of small single-board computers developed in the United Kingdom by the raspberry pi foundation to put the power of computing and digital making into the hands of people all over the world. If at the beginning the aims of raspberry pi project were leaned towards the promotion of teaching of basic computer science in schools and in developing countries, it rapidly expanded into a wider range of use, as the original model become very popular than anticipated.

Raspberry pi is a low cost, credit-card sized computer that plugs into a computer monitor or TV and uses a standard keyboard and mouse. It is a capable little device that enables people of all ages to explore computing, and to learn how to program in languages like scratch and python. It's capable of doing everything you'd expect a desktop computer to do, from browsing the internet and playing high-definition video, to making spreadsheets, word-processing, and playing games.

The raspberry pi has the ability to interact with the outside world and has been used in a wide array of digital maker projects, from music machines and parent detectors to weather stations and tweeting birdhouses with infra-red cameras. We want to see the raspberry pi being used by kids all over the world to learn to program and understand how computers work.

4.1.1 Generations

Several generations of raspberry pi have been released. All models feature a Broadcom system on a chip (soc) with an integrated ARM-compatible central processing unit (CPU) and on-chip graphics processing unit (GPU). Processor speed ranges from 700 MHz to 1.4GHz for the pi3 model B+ or 1.5GHz for pi 4; onboard memory ranges from 256 MiB to 1 GiB random-access memory (RAM), with up to 8 GiB available on the pi 4. Secure digital (SD) cards in micro SDHC form factor (SDHC on early models) are used to store the operating system and program memory. The boards have one to five USB ports for video output, HDMI and composite video are supported, with a standard 3.5mm tip-ring-sleeve jack for audio output. Lower-level output is provided by a few GPIO pins, which support common protocols like I2C. the B-models have an 8P8C Ethernet port and the pi 3, pi 4 and pi zero W have on board Wi-Fi 802.11n and Bluetooth.

The first generation (Raspberry pi model B) was released in February 2012, followed by simpler and cheaper model A. in 2014, the foundation released a board with an improved design, raspberry pi model B+. these boards are appropriately credit-card sized and represent the standard mainline formfactor. Improved A+ and B+ models were released a year later. A “compute module” was released in April 2014 for embedded applications. The raspberry pi 2, which featured a 900 MHz quad-core ARM cortex-A7 processor and 1GiB RAM, was released in February 2015 A raspberry pi zero with smaller size and reduced input/output (i/o) and general-purpose (GPIO) capabilities was released in November 2015. On 28 February 2017, the raspberry pi zero W was launched, a version of the zero with Wi-Fi and Bluetooth capabilities, on 12 January 2018, the raspberry pi zero WH was launched. A version of the zero W with pre-soldered GPIO headers.

Raspberry pi 3 model B was released in February 2016 with a 1.2GHz 64-bit quad core processor, on-board 802.11n WiFi, Bluetooth and USB boot capabilities. On pi day 2018, the raspberry pi 3 model B+ was launched with a faster 1.4GHz processor and a three-times faster gigabit Ethernet (throughput limited to ca. 300 Mbit/s by the internal USB 2.0 connections) or 2.4/5 GHz dual band 802.11ac Wi-Fi (100 Mbit/s). Other features are power over Ethernet (PoE) (with the add-on PoE HAT), USB boot and network boot (as SD card is no longer required).

Raspberry pi 4 model B was released in June 2019 with a 1.5 GHz 64-bit quad core ARM cortex-A72 processor, on-board 802.11ac Wi-Fi, Bluetooth 5, full gigabit Ethernet (throughput not limited), two USB 2.0 ports, two USB 3.0 ports, and dual-monitor support via a pair of micro-HDMI (HDMI type D) ports for upto 4K resolution. The pi 4 is also powered via a USB-C port, enabling additional power to be provided to downstream peripherals, when used with an appropriate PSU. The initial raspberry pi 4 board has a design flaw where third-party e-marked USB cables, such as those used on apple MacBook’s, incorrectly identify it and refuse to provide power. Tom’s hardware tested 14 different cables and founded that 11 of them turned on and powered the pi without issue. The design flaw was fixed in revision 1.2 of the board, released in late 2019.

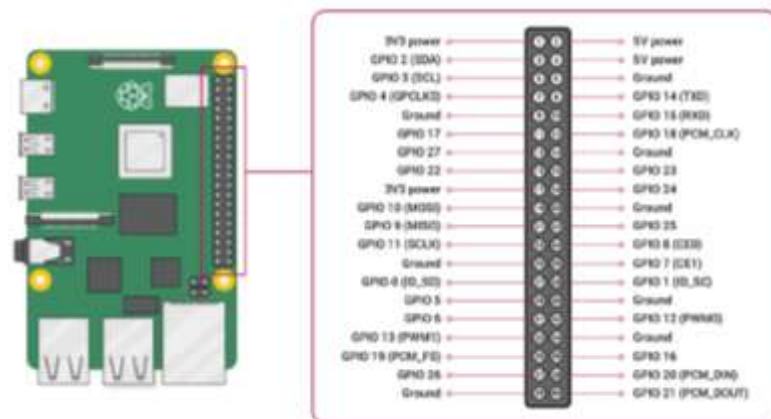

Fig.8. Raspberry Pi pin diagram

4.2 TOUCH SCREEN:

The raspberry pi touch display is an LCD display which connects to the raspberry pi through The DSI connector. In some situations, it allows for the use of both the HDMI and LCD displays at thesame time.

The DSI display is designed to work with all models of raspberry pi, however early models thatdo not have mounting holes (the raspberry pi 1 model A and B) will require additional mountinghardware to fit the HAT-dimensioned stand-offs on the display PCB.



Fig. 9. Touch screen

The following image shows how to attach the raspberry pi to the back of the touch display (if required), and how to connect data (ribbon cable) and power (red/black wires) from the raspberry pi to the display. If you are not attaching the raspberry pi to the back of the display, take extra care when attaching the ribbon cable to ensure it is the correct way round. The black and red power wires should be attached to the GND and 5v pins respectively.

4.3 MICROPHONE:

Several types of microphones are used today, which employ different methods to convert the air pressure variations of a sound wave to an electrical signal the most common are the dynamic microphone, which uses a coil of wire suspended in a magnetic field; the condenser microphone, which uses the vibrating diaphragm as a capacitor plate; and the contact microphone, which uses a crystal of piezoelectric material. Microphones typically need to be connected to a preamplifier before the signal can be recorded or reproduced.

Microphones are used in many applications such as telephones, hearing aids, public address systems for concert halls and public events, motion picture production, live and recorded audio engineering, sound recording, two-way radios, megaphones, radio and television broadcasting. They are also used in computers for recording voice, speech recognition, voice, and for non-acoustic purposes such as ultrasonic sensors or knock sensors.



Fig. 10. Microphone

This is a tiny USB microphone that plugs into your laptop or desktop computer. No microphone on your computer? No problem-just plug this incredibly small microphone into a USB port and add microphone functionality. No need to install any extra software; Microsoft windows will detect the device and automatically install it. Simply launch within any program such as skype or googlehangouts. There is no need to configure the USB mini microphone, it can be used directly.

4.4 PIR SENSOR:

The passive infrared sensor (PIR) sensor module is used for motion detection. It is often referred to as "PIR", "pyroelectric", "passive infrared" and "IR motion" sensor. The module has a non-board pyroelectric sensor, conditioning circuitry and a dome shaped Fresnel lens. It is used to sense movement of people, animals, or other objects. They are commonly used in burglar alarms and automatically-activated lighting systems.



Fig. 11. PIR sensor

Passive infrared sensor (PIR sensor) is an electronic sensor that measures infrared (IR) light radiating from objects in its field of view. They are most often used in PIR-based motion detector (PID).

PIR sensors are commonly called simply “PIR”, or sometimes “PID”, for “passive infrared detector”. The term passive refers to the fact that PIR devices do not radiate energy for detection purposes. They work entirely by detecting infrared radiations (radiant heat) emitted by or reflected from objects.

5. CONCLUSION

The main theme of the proposed work is to design a product bundled with maximum possible features. The system is not just devised as a means of information provider but also an interactive system which can actively be used for security and to control home appliances. The system can be used as security and vigilance system. There is no absolute need of personal monitoring. This system is very useful for physically challenged people, old people and children. Most importantly everyone can easily access this system easily even while doing their daily chorus. The system can be extended as a commercial product. There is a scope of future work in this proposed system by adding artificial intelligence, controlling smart mirror with hand gestures.

6. REFERENCES

- [1] Divyashree K.J, Dr. P.A. Vijaya, Nitin Awasthi, “Design And Implementation Of Smart Mirror As A Personal Assistant Using Raspberry PI,” International Journal of Innovative Research in Computer and Communication Engineering Vol. 6, Issue 3, March 2018.
- [2] D.K. Mittal, V. Verma, R. Rastogi, “A Comparative Study and New Model for Smart Mirror,” International Journal of Scientific Research in Research Paper, Computer Science and Engineering, Vol. 5, Issue. 6, pp. 58-61, December -2017.
- [3] Dr. J. Ajayan, P. Santhosh Kumar, S. Saravanan, S. Sivadharini, R. Sophia5, “Development of Smart Mirror using Raspberry-Pi 3 for Interactive Multimedia,” 12th International conference on Recent Innovations in Science and Management ICRISEM’-2018.
- [4] Prof. Jagdish A, Patel Jayshri T, Sadgir Sonal D, Sangaleharshada A. Dokhale, “A Review Paper Design and Development of a Smart Mirror Using Raspberry Pi” International Journal of Engineering Science Invention Vol. 7, Iss. 4, pp. 40-43.
- [5] Prof. Manish Assudani, A. S. Kazi, P.O.Sherke, S. V. Dwivedi, Z. S. Shaikh, “Hermione 1.0”- A voice Based Home Assistant System”, National Conference on Advances in Engineering and Applied Science (NCAEAS) 29th January 2018.
- [6] Kun Jin, Xibo Deng, Zhi Huang, ShaoChang Chen, “Design of Smart Mirror based on Raspberry Pi,” 2018 2nd IEEE Advanced Information Management, Communicates, Electronic and Automation Control Conference (IMCEC 2018).

- [7] Lakshmi N M, Chandana M S, “IoT based Smart Mirror using Raspberry Pi,” *International Journal of Engineering Research & Technology (IJERT)*, Volume 6, Issue 13 -2018.
- [8] Suryansh Chandel, 2Ashay Mandwarya, 3S.Ushasukhanya, “Implementation Of MagicMirror Using Raspberry PI 3”, *International Journal of Pure and Applied Mathematics* Volume 118 No. 22 2018, 451-455 -2018
- [9] P. Chandra Shaker, V. Parameswaran, M. Srikanth, V. Vijay, V. Siva Nagaraju, S.C. Venkateswarlu, Sadulla Shaik, and Vallabhuni Rajeev Ratna, “Realization and Comparative analysis of Thermometer code based 4-Bit Encoder using 18nm FinFET Technology for Analog to Digital Converters,” *Advanced Intelligent Systems and Computing (AISC)*, 2020.
- [10] Mohammad Khadir, Kancharapu Chaitanya, S. Sushma, V. Preethi, and Vallabhuni Vijay, “Design Of Carry Select Adder Based On A Compact Carry Look Ahead Unit Using 18nm Finfet Technology,” *Journal of Critical Reviews*, vol. 7, iss. 6, 2020, pp. 1164–1171.
- [11] Rajeev Ratna Vallabhuni, D.V.L. Sravya, M. Sree Shalini, and G. Uma Maheshwararao, “Design of Comparator using 18nm FinFET Technology for Analog to Digital Converters,” *2020 7th International Conference on Smart Structures and Systems (ICSSS)*, Chennai, India, 23-24 july, 2020, pp. 318–323.
- [12] Shaik, Sadulla, Anil Kumar Kurra, and A. Surendar, “High secure buffer based physical unclonable functions (PUF's) for device authentication,” *Telkomnika*, 17, no. 1, 2019.
- [13] Vallabhuni Vijay, P. Chandra Shekar, V. Siva Nagaraju, S. China Venkateswarlu, and Shaik Sadulla, “High Performance 2:1, 4:1 And 8:1 Binary And Ternary Multiplexer Realization Using CNTFET Technology,” *Journal of Critical Reviews*, vol. 7, iss. 6, 2020, pp. 1159–1163.
- [14] Sai Lakshmi, Taninki, Avireni Srinivasulu, and Pittala Chandra Shaker, “Implementation of power efficient flash analogue-to-digital converter,” *Active and Passive Electronic Components*, 2014.
- [15] Kurra, Anil Kumar, and Usha Rani Nelakuditi, “A secure arbiter physical unclonable functions (PUFs) for device authentication and identification,” *Indonesian Journal of Electrical Engineering and Informatics (IJEEI)*, 7, no. 1, 2019, pp. 117–127.
- [16] Vallabhuni Vijay, V. Siva Nagaraju, M. Sai Greeshma, B. Revanth Reddy, U. Suresh Kumar, and, C. Surekha, “A Simple and Enhanced Low-Light Image Enhancement Process Using Effective Illumination Mapping Approach,” *Lecture Notes in Computational Vision and Biomechanics*, Cham, Switzerland. 2019, pp. 975–984.
- [17] Kurra, A.K., and Sadulla, S., “Analysis of physical unclonable functions (PUFS) for secure key generation on smartcard chips,” *Journal of Advanced Research in Dynamical and Control Systems*, 9, 2017, pp. 1735-1745.
- [18] Vallabhuni Vijay, “Second Generation Differential Current Conveyor (DCCII) And Its Applications,” *Vignana's Foundation for Science, Technology & Research (Deemed to be University)*, Guntur, 2017.
- [19] Rajeev Ratna Vallabhuni, J. Sravana, M. Saikumar, M. Sai Sriharsha, and D. Roja Rani, “An advanced computing architecture for binary to thermometer decoder using 18nm FinFET,” *2020 Third International Conference on Smart Systems and Inventive Technology (ICSSIT)*, Tirunelveli, India, 20-22 August, 2020, pp. 510–515.
- [20] P. Saritha, J. Vinitha, S. Sravya, V. Vijay, and E. Mahesh, “4-Bit Vedic Multiplier with 18nm FinFET Technology,” *2020 International Conference on Electronics and Sustainable Communication Systems (ICESC)*, Coimbatore, India, 2020, pp. 1079–1084.

- [21] Vijay, V., J. Prathiba, S. Niranjana Reddy, and P. Praveen Kumar, "A REVIEW OF THE 0.09 μm STANDARD FULL ADDERS," *International Journal of VLSI Design & Communication Systems*, vol. 3, no. 3, 2012, p. 119.
- [22] Kurra, Anil, and Usha Rani Nelakuditi, "Design of a Reliable Current Starved Inverter Based Arbiter Physical Unclonable Functions (PUFs) for Hardware Cryptography," *Ingénierie des Systèmes d'Inf.*, 24, no. 4, 2019, pp. 445–454.
- [23] V. Vijay, and Avireni Srinivasulu, "Tunable Resistor and Grounded Capacitor Based Square Wave Generator Using CMOS DCCII," *International J. Control Theory and Applications*, vol. 8, 2015, pp. 1–11.
- [24] Kurra, Anil Kumar, and Usha Rani Nelakuditi, "A Decoder-Mux Based Arbiter Physical Unclonable Functions for Low Cost Security Applications," In 2019 International Conference on Communication and Electronics Systems (ICCES), 2019, pp. 1473–1477.
- [25] Shaik, Sadulla, Anil Kumar Kurra, and A. Surendar, "Statistical Analysis of Arbiter Physical Unclonable Functions using Reliable and Secure Transmission Gates," *International Journal of Simulation--Systems, Science & Technology*, 19, no. 4, 2018.
- [26] Rajeev Ratna Vallabhuni, K.C. Koteswaramma, B. Sadgurbabu, and Gowthamireddy A, "Comparative Validation of SRAM Cells Designed using 18nm FinFET for Memory Storing Applications," *Proceedings of the 2nd International Conference on IoT, Social, Mobile, Analytics & Cloud in Computational Vision & Bio-Engineering (ISMAL-CVB 2020)*, 2020, pp. 1-10.
- [27] Vallabhuni Vijay, and Avireni Srinivasulu, "A low power waveform generator using DCCII with grounded capacitor," *International Journal of Public Sector Performance Management*, vol. 5, 2019, pp. 134–145.
- [28] P. Chandrashekar, R. Karthik, O. Koteswara Sai Krishna, and Ardhi Bhavana, "Design of low threshold Full Adder cell using CNTFET," *International Journal of Applied Engineering Research*, vol. 12, no. 12, 2017, pp. 3411–3415.
- [29] V. Vijay, and Avireni Srinivasulu, "A square wave generator using single CMOS DCCII," in *proceedings of the 2013 IEEE International SoC Design Conference (IEEE ISoCC-2013)*, Busan, South Korea, November 17-19, 2013, pp. 322–325.
- [30] Rajeev Ratna Vallabhuni, G. Yamini, T. Vinitha, and S. Sanath Reddy, "Performance analysis: D-Latch modules designed using 18nm FinFET Technology," 2020 International Conference on Smart Electronics and Communication (ICOSEC), Tholurpatti, India, 10-12, September 2020, pp. 1171–1176.
- [31] Sai Lakshmi, Taninki, Avireni Srinivasulu, and Pittala Chandra Shaker, "Implementation of power efficient flash analogue-to-digital converter," *Active and Passive Electronic Components*, 2014.
- [32] Vallabhuni Vijay, and Avireni Srinivasulu, "A Novel Square Wave Generator Using Second Generation Differential Current Conveyor," *Arabian Journal for Science and Engineering*, vol. 42, iss. 12, 2017, pp. 4983–4990.
- [33] Pittala Chandra Shaker, and Avireni Srinivasulu, "Quadrature oscillator using operational transresistance amplifier," 2014 International Conference on Applied Electronics, Pilsen, Czech Republic, Sept. 2014, pp. 117–120.
- [34] V. Vijay, and Avireni Srinivasulu, "A DCCII Based Square Wave Generator With Grounded Capacitor," in *proceedings of the 2016 IEEE International Conference on Circuits, Power and Computing Technologies (IEEE ICCPCT-2016)*, Kumaracoil, India, March 18-19, 2016, pp. 1–4.
- [35] Krishna, VVS Vijay, A. Monisha, Sk Sadulla, and J. Prathiba, "Design and implementation of an automatic beverages vending machine and its performance

- evaluation using Xilinx ISE and Cadence,” In 2013 Fourth International Conference on Computing, Communications and Networking Technologies (ICCCNT), IEEE, 2013, pp. 1–6.
- [36] Vallabhuni Rajeev Ratna, P. Shruthi, G. Kavya, and S. Siri Chandana, “6Transistor SRAM Cell designed using 18nm FinFET Technology,” Proceedings of the Third International Conference on Intelligent Sustainable Systems [ICISS 2020], Palladam, India, December 4-5, 2020, pp. 1181-1186.
- [37] Rajeev Ratna Vallabhuni, A. Karthik, CH. V. Sai Kumar, B. Varun, P. Veerendra, and Srisailam Nayak, “Comparative Analysis of 8-Bit Manchester Carry Chain Adder Using FinFET at 18nm Technology,” Proceedings of the Third International Conference on Intelligent Sustainable Systems [ICISS 2020], Palladam, India, December 4-5, 2020, pp. 1158-1162.
- [38] Manchala Sreeja, Vallabhuni Vijay, “A Unique Approach To Provide Security For Women By Using Smart Device,” European Journal of Molecular & Clinical Medicine, vol. 7, iss. 1, 2020, pp. 3669-3683.
- [39] V. Vijay, and Avireni Srinivasulu, “Grounded Resistor and Capacitor based Square Wave Generator using CMOS DCCII,” in proceedings of the 2016 IEEE International Conference on Inventive Computation Technologies (IEEE ICICT-2016), Coimbatore, India, August 26-27, 2016, pp. 79–82.
- [40] V. Siva Nagaraju, P. Ashok Babu, Vallabhuni Rajeev Ratna, Ramya Mariserla, “Design and Implementation of Low Power 32-bit Comparator,” Proceedings of the International Conference on IoT Based Control Networks and Intelligent Systems (ICICNIS 2020), Palai, India, December 10-11, 2020, pp. 1-8.
- [41] B.M.S Rani, Divyasree Mikkili, Rajeev Ratna Vallabhuni, Chandra Shaker Pittala, Vijay Vallabhuni, Suneetha Bobbillapati, H. Bhavani Naga Prasanna, “Retinal Vascular Disease Detection from Retinal Fundus Images Using Machine Learning,” Australia patent 2020101450.
- [42] Venkateswarlu, S.C., Kumar, N.U., Kumar, N.S., Karthik, A., and Vijay, V., “Implementation of Area optimized Low power Multiplication and Accumulation,” International Journal of Innovative Technology and Exploring Engineering (IJITEE), vol. 9, iss. 9, 2019, pp. 2278–3075.
- [43] Vallabhuni Rajeev Ratna, M. Saritha, Saipreethi. N, V. Vijay, P. Chandra Shaker, M. Divya, Shaik Sadulla, “High Speed Energy Efficient Multiplier Using 20nm FinFET Technology,” Proceedings of the International Conference on IoT Based Control Networks and Intelligent Systems (ICICNIS 2020), Palai, India, December 10-11, 2020, pp. 1-8.
- [44] V. Vijay, J. Prathiba, S. Niranjana reddy, Ch. Srivalli, and B. Subbarami reddy, “Performance evaluation of the CMOS Full adders in TDK 90 nm Technology,” International Journal of Systems, Algorithms & Applications, vol. 2, iss. 1, 2012, pp. 711.
- [45] Pittala Chandra Shaker, and Avireni Srinivasulu, “Two simple sinusoidal oscillators using single operational transresistance amplifier,” In 2015 3rd International Conference on Signal Processing, Communication and Networking (ICSCN), Chennai, India, March 2015, pp. 1–5.
- [46] Rajeev Ratna Vallabhuni, S. Lakshmanachari, G. Avanthi, and Vallabhuni Vijay, “Smart Cart Shopping System with an RFID Interface for Human Assistance,” Proceedings of the Third International Conference on Intelligent Sustainable Systems [ICISS 2020], Palladam, India, December 4-5, 2020, pp. 497-501.

- [47] K. Nagalakshmi, Avireni Srinivasulu, Cristian Ravariu, V. Vijay, V. V. Krishna, "A novel simple schmitt trigger circuit using CDTA and its application as a square-triangular waveform generator," J. Mod. Technol. Eng, vol. 3, 2018, pp. 205-216.