

Original Research Article

CORRELATION OF ANTENATAL ULTRASOUND UMBILICAL ARTERY COILING INDEX AT SECOND TRIMESTER ULTRASONOGRAPHY WITH PERINATAL FOETAL OUTCOME

¹Dr. Shreyas Rao G, ²Dr. Prashanth K S, ³Dr. Anil Sangappa Savalagi,
⁴Dr. Anand Madappanavar

¹Senior Resident, Department of Radiodiagnosis, Shimoga Institute of Medical Sciences (SIMS), Shimoga, Karnataka, India

^{2,3,4}Senior Resident, Department of Radiodiagnosis, Belgaum Institute of Medical Sciences (BIMS), Belgaum, Karnataka, India

Corresponding Author:

Dr. Anand Madappanavar

Abstract

Objectives: To evaluate the perinatal fetal outcome in correspondence with the second-trimester scan umbilical artery coiling index in uncomplicated singleton pregnancies.

Method: A prospective analytical study was performed for a duration of six months. A total of 154 Singleton pregnancies scheduled to be delivered in tertiary care centre were taken into the study. The evaluation of the umbilical cord mid-segment (free loop) included the recording of longitudinal cord images for the assessment of cord coiling. The antenatal UCI was calculated as the reciprocal of the distance between a pair of coils. After calculating the UCI, perinatal factors like meconium staining, fetal weight, and Apgar score were followed till discharge. For the classification of newborns as SGA, gestational age-specific centiles were used. The mean antenatal UCI was 0.40 with 10th and 90th centiles of 0.20 and 0.60, respectively³. The statistical tests were the Chi-square test and assessed with SPSS version 13.0 software and statistically analyzed. A p-value of less than 0.05 was regarded as statistically significant.

Results: In the present study, it was observed that meconium staining was significantly associated with UCI <10th percentile. Apgar score <7 at 1 min and 5 min was found with UCI <10th percentile of hypocoiled cords. No statistical significance was noted with the antenatal umbilical cord coiling index and fetal weight with respect to its gestational age with an insignificant p-value.

Keywords: meconium, Apgar score, umbilical cord coiling index

Introduction

The umbilical cord is vital for the development of the fetus, yet is vulnerable to kinking, compressions, traction and torsion affecting the perinatal outcome. The origin of umbilical cord coiling is unknown. Hypotheses include fetal movements, active or passive torsion of the embryo, differential umbilical vascular growth rates, fetal hemodynamic forces and the arrangements of muscular fibres in the umbilical arterial wall. Of the many characteristics of

the human umbilical cord, the most mysterious and intriguing one is the twisted or spiral course of its component blood vessels.

The coiling of the umbilical cord has been the subject of anatomical and sonographic study. In modern literature, Edmonds was the first to consider the anatomy and described it as an "index of twist"^[1]. Based on a concept that abnormal vasculogenesis and/or development of the Wharton's jelly ground substance might be a marker for adverse fetal growth and obstetric outcomes, several studies of cords examined postnatally have explored possible associations between coiling and outcomes. As a basis for such studies, the normal range for coiling at birth following uncomplicated singleton pregnancies was established.

The coiling of the umbilical vessels develops as early as 28 days after conception and is present in about 95% of fetuses by 9 weeks of conception. The helices may be seen by ultrasonographic examination as early as during the first trimester of pregnancy^[2].

Extending the concept into the antenatal period, a detailed review considered the development and structure of the umbilical cord and examined the rationale and potential to take advantage of sonography to identify abnormal coiling in utero as a marker of fetal compromise. The antenatal umbilical coiling index (UCI) is calculated as the reciprocal value of the distance between a pair of coils^[2].

$UCI = 1/DISTANCE\ IN\ CMS.$

A frequency distribution of the umbilical cord index (UCI) was done by Rana *et al.* (1995)^[3]. They grouped the UCI as follows: >90th percentile as hypercoiled and <10th percentile as hypocoiled. The difference in coiling was described as an antenatal marker identifying fetus at risk. The majority of the studies on UCI have been done postnatally. Although UCI can be calculated antenatally by ultrasonography, limited data is available. Thus, this study forms a cornerstone in the early prediction as the antenatal UCI below the 10th or above the 90th centile has been reported to be associated with a higher prevalence of non-reassuring fetal status in labour and small-for-gestational-age SGA neonates^[4]. The aim of this study was to evaluate whether a relationship exists between aberrant umbilical coiling patterns in the second trimester and to elucidate a possible mechanism that associates antenatal UCI with adverse perinatal outcomes.

Aims and Objectives

To evaluate the perinatal fetal outcome in correspondence with the second-trimester scan umbilical artery coiling index in uncomplicated singleton pregnancies.

Materials and Methods

Source of data: Participants were recruited in the ultrasound unit at the tertiary care hospital.

Study design: This was a prospective study.

Study period: Six months.

Sample size: 154 cases.

Inclusion criteria: Singleton pregnancy scheduled to be delivered in our hospital.

Exclusion criteria

- Multifetal gestation.
- Anomalous fetus.
- Single umbilical artery.

- Inadequate demographic, antenatal or labour data.
- An inadequate longitudinal image of the umbilical cord to allow an accurate antenatal UCI measurement.
- Inadequate or incomplete Doppler studies of the umbilical vessels.

All ultrasound examinations were performed using a 6-MHz transabdominal transducer, with multi-hertz and harmonic capability. The evaluation of the umbilical cord mid-segment (free loop) included the recording of longitudinal cord images for the assessment of cord coiling. The antenatal UCI was calculated as the reciprocal of the distance between a pair of coils. After calculating the UCI, perinatal factors like meconium staining, fetal weight, and Apgar score were followed till discharge. For the classification of newborns as SGA, gestational age-specific centiles were used. The mean antenatal UCI was 0.40 with 10th and 90th centiles of 0.20 and 0.60, respectively^[3].

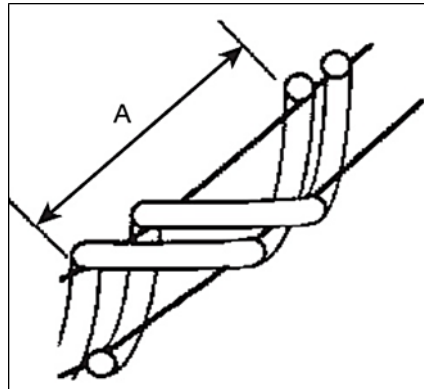

The distance between the coils was measured from the inner edge of an arterial wall to the outer edge of the same artery along the ipsilateral side of the umbilical cord

Statistical analysis

Data were entered and managed in the Microsoft Excel 2010 spreadsheet. Variables were tabulated and summarized into means or medians for continuous variables and percentages for categorical variables. The baseline characteristics of maternal age and parity were compared between groups with normal and abnormal cord coiling to ascertain their comparability.

The prevalence of SGA and preterm birth was calculated and presented as a percentage for each group with the relative risk and associated 95% CI. The sensitivity, specificity, and predictive value of UCI for SGA and preterm birth were estimated as a guide to the potential clinical usefulness of the index. Furthermore, the risk differences between the two groups were adjusted for potential differences in their baseline characteristics. Chi-square test was used to determine the significance of differences between categorical variables and t-test was used to compare means, all using a 5% significance level.

Results

Of the 200 patients initially included, 32 were excluded from the study on the basis of-

- Delivery at other institutions (17 patients).
- Multifetal gestation (09 patients).
- Presence of gross fetal anomalies (04 patients).
- Presence of two-vessel umbilical cord (02 patients).

- Inadequate sonographic umbilical cord image and/or all maternal demographic, antenatal and labour data and Intrauterine death were excluded (14 patients).

Thus 154 patients formed the final study group. The mean \pm SD gestational age at the time of the fetal anatomical ultrasound survey was 20.3 \pm 0.9 weeks and the mean maternal age was 24.4 \pm 4.2 years. The majority of patients delivered at term and the mean gestational age at delivery was 39.5 \pm 1.8 (range, 30-41) weeks of gestation. The mean antenatal UCI was 0.40 with 10th and 90th centiles of 0.20 and 0.60, respectively.

Characteristics (Mean \pm -SD)	Umbilical Artery Coiling		
	Hypocoiling (<10 Centile)	Normal Ceiling	Hypercoiling (>90 Centile)
N	21	119	14
Maternal Age (YRS)	24.8 \pm 4.2	25.6 \pm 5.0	25.8 \pm 5.1
Gestational Age at Ultrasound (WKS)	20.7 \pm 0.4	20.2 \pm 0.8	20.1 \pm 0.7
Gestational Age at Delivery (WKS)	39.5 \pm 1.2	39.3 \pm 1.7	39.4 \pm 1.1

Table 1: Maternal demographic and neonatal birth-weight data stratified according to antenatal umbilical cord coiling index results

Weight for Gestational Age at Birth	Antenatal Umbilical Artery Coiling Index Category			
	Hypocoiling	Normal	Hypercoiling	Total
Small	10	6	4	23
Normal	9	99	8	113
Large	2	14	2	18
Total	21	119	14	154

Using the intergrowth newborn weight for gestational age standards, 23 (14.9%) of the neonates were classified as SGA, 113 (73.4%) as normal for gestational age (NGA) and 18 (11.6%) as large for gestational age (LGA). The distribution of the SGA, NGA and LGA in the normocoiled, hypocoiled and hypercoiled groups is shown in Table 2.

The sensitivity, specificity, positive predictive value (PPV), and negative predictive value (NPV) of abnormal coiling for predicting SGA were 20%, 75%, 9.8% and 87.4%, respectively. The odds ratio (OR) for the association between abnormal coiling index versus SGA at birth was 0.7 (95% CI: 0.3-1.6, $P = 0.445$). After adjusting for potential confounders using multivariable logistic regression models, there was no significant change in the above estimate with an OR of 0.6 (95% CI: 0.32-1.4, $P = 0.26$).

Out of 154 cases studied 19 (12.4%) had meconium-stained liquor. Out of which 3 (20.0%) had normal ceiling, 14 (74%) had hypocoiling and 2 (4%) had hypercoiling. 135 (88.0%) cases did not have meconium-stained liquor. Out of them 116 (95.4%) had normal ceiling, 7 (26%) had hypocoiling and 12 (96.0%) had hypercoiling, which was statistically strongly significant with P -value being <0.001 ($p < 0.01$) is strongly significant. Meconium staining is more in hypocoiled group.

The correlation of Apgar scores at 1 minute with UCI. Out of a total of 107 patients who had their Apgar score >7 , 91 had normal UCI, 5 had hypo coiling and 11 had hyper coiling. In Apgar score <7 at 1, minute out of a total of 47 (30.4%) patients, 28 had normal UCI while 16 had hypo coiling and 3 patients had hyper coiling. On applying the chi-square test, the difference was found statistically highly significant ($p < 0.001$).

Correlation of Apgar scores at 5 minutes with UCI. Out of a total of 106 patients who had their Apgar score >7 , 90 had normal UCI, 6 had hypo coiling and 10 had hyper coiling.

In Apgar score <7 at 5 minutes, out of a total of 48 patients, 29 had normal UCI while 15 had hypo coiling and 4 patients had hyper coiling. On applying the chi-square test, the difference was found statistically highly significant ($p < 0.001$).

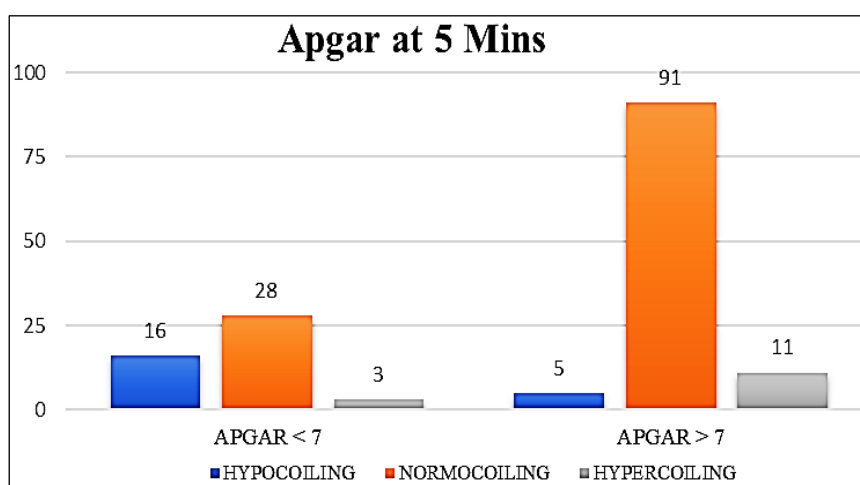
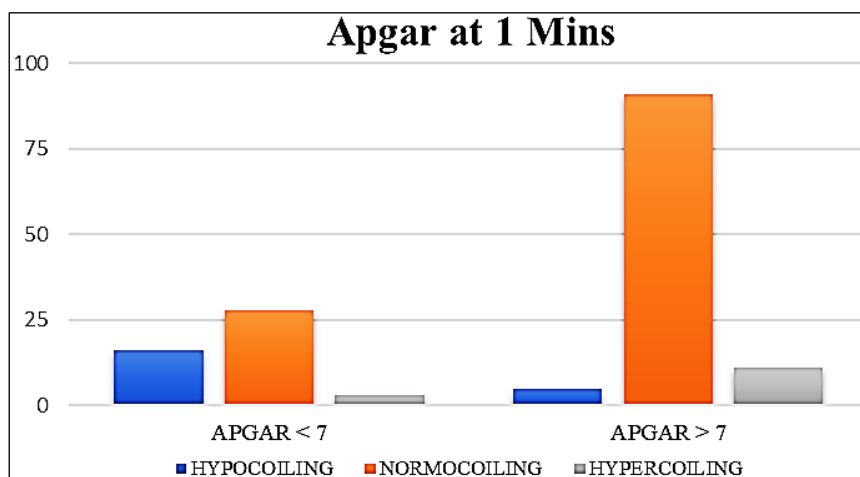

Conclusion

1. In the present study, it was observed that meconium staining was significantly associated with UCI <math>< 10^{\text{th}}</math> percentile.

Past studies corroborating the result: Gupta *et al.* studied 107 umbilical cords and found that in the hypo coiling group, meconium staining was significantly higher than those with the normal coiling group^[5]. Strong *et al.* studied 100 umbilical cords and found that meconium staining was associated with UCI values <math>< 10^{\text{th}}</math> percentile, with a p-value of 0.03 which is highly significant^[4].

2. Apgar score <math>< 7</math> at 1 min and 5min was found with UCI <math>< 10^{\text{th}}</math> percentile of hypocoiled cords.

Past studies corroborating the result: This was explained by an experiment by Georgiou *et al.* in which venous perfusion was measured in cords subjected to standardized tight encirclement force. A significant inverse relationship was found between the coiling index and the minimum weight required to occlude venous perfusion. So, hypocoiling may give way to kinking and compression, whereas, hypercoiling may give way to occlusion in cases with cord entanglement. This may help to explain, the association with a low Apgar score in hypocoiled cords^[6].

3. In the present study, no statistical significance was noted with the antenatal umbilical cord

coiling index and fetal weight with respect to its gestational age with an insignificant p-value. However past studies conducted by Monique *et al.* [7]. Who studied 885 cases, found that hypo-coiling was associated with small gestational age infants. Georgiou *et al.* [6]. Studied 34 cases and found that IUGR was found in hyper-coiled group.

References

1. Edmonds HW. The spiral twist of the normal umbilical cord in twins and in singletons. *Am J ObstetGynecol.* 1954;67:102-20.
2. Raio L, Ghezzi F, Franchi M, Maymon E, Mueller MD, Bruhwiler H. Prenatal diagnosis of a lean umbilical cord: a simple marker for the fetus at risk of being small for gestational age at birth. *Ultrasound ObstetGynecol.* 1999;13:176-180.
3. Van Diik CC, Franx A, De Laat MW, Bruinse HW, Visser GH, Nikkels PG. The umbilical coiling index in normal pregnancy. *J MaternFetal Neonatal Med.* 2002;11:280-3.
4. Strong Jr.TH, ElliottJP, RadinTG. Non-coiled umbilical blood vessels: a new marker for the fetus at risk, *Obstetrics and Gynecology.* 1993;81(3):409-411.
5. Padmanabhan LG, Mhaskar R, Mhaskar A. Umbilical vascular coiling and the perinatal outcome. *J ObstetGynecol India.* 2001;51:43-4.
6. Georgiou HM, Rice GE, Walker SP. The effect of vascular coiling on venous perfusion during experimental umbilical cord encirclement. *Am J Obstet Gynecol.* 2001;184:673-8.
7. Monique de Laat WM, Frank A, Bots M. Umbilical coiling index in normal and complicated pregnancies. *Obstet Gynecol.* 2006;107:1049-55.